

# DuraMAC™

## Water Pressure Booster System



See Pumps and Accessories Price List for Limited Warranty Details.



**PUMPS**  
**WATERWORKS**  
**PLUMBING VALVES**  
**GAS VALVES**

800.292.2737 | FAX 800.832.9296  
pumps@aymcdonald.com

[www.aymcdonald.com](http://www.aymcdonald.com)



The DuraMAC™ Booster System was built with one simple goal in mind - to be the World's Most Versatile Booster System.

### Versatile

It is the first booster pump of its kind to be designed for virtually all boosting applications. In Pressure Mode, the pump starts with pressure drop and stops on low flow. In Flow Mode, the pump starts and stops by sensing flow. In Conservation Mode, the pump only operates during a peak demand, such as when multiple showers, bathtubs, or irrigation systems running.

### Simple

A single-speed, totally enclosed fan-cooled motor drives the DuraMAC™ booster pump with single phase power. It is controlled with one dial and tells you it is working properly by illuminating a single status light. The settings and readouts are simple and straight forward.

### Sophisticated

A pressure transducer constantly monitors system pressure and alerts the pump control to start the pump as water in the system is used. The pump then stays on, boosting the system pressure until the need for water is no longer present, indicated by low flow.

### Reliable

Electronic components are completely separated from piping and water ways for added safety and ease of field repair. The DuraMAC™ is built from scratch with one purpose in mind - boosting water pressure. Each component of the system is specifically designed to work together, as one harmonious unit. The result is a complete package backed by an industry leading three year warranty.

### How It Works

The DuraMAC™ Water Pressure Boosting System can be set to three separate modes, which can accommodate virtually any application.



#### PRESSURE MODE

START METHOD: Pressure drop

STOP METHOD: Low flow

TYPICAL INSTALLATION: Appropriate for the majority of light commercial or residential applications

RESULT: Pump operates continuously while there is a need for water



#### CONSERVATION MODE

START METHOD: Pressure drop

STOP METHOD: Low Flow

TYPICAL INSTALLATION: Application where pressure is adequate for most uses, and boosting is only necessary for high demand

RESULT: Pump will operate only when system pressure is below city supplied pressure and operates continuously while there is demand for water



#### FLOW MODE

START METHOD: Water flow

STOP METHOD: Low flow

TYPICAL INSTALLATION: Application where pressure fluctuates, or occasional system leaks are present

RESULT: Pump operates when usage of water exceeds approximately one gallon per minute



# DuraMAC™

## Water Pressure Booster System



# The World's Most Versatile Booster System

## Light Commercial/Irrigation & Residential Boosters

### Typical Installations

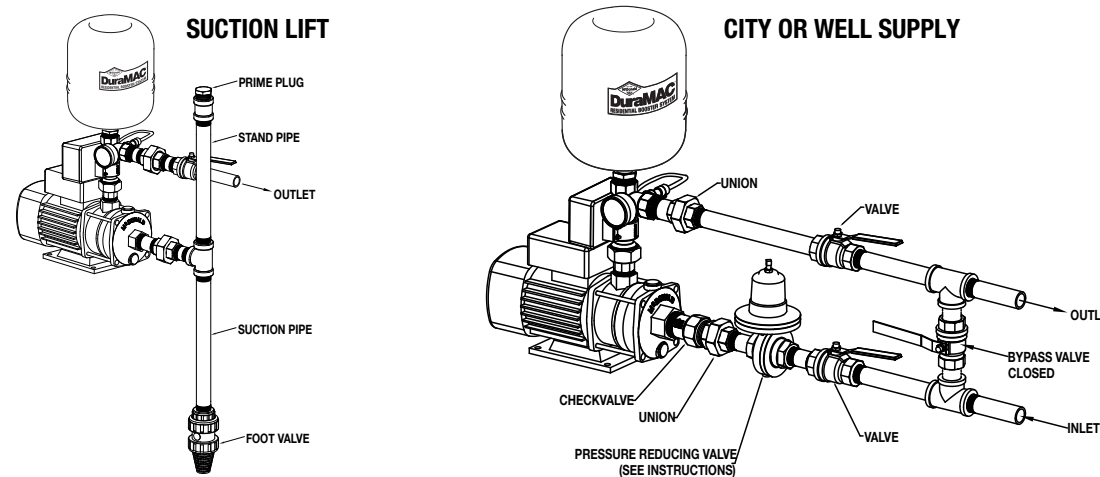

### Specifications/Dimensions

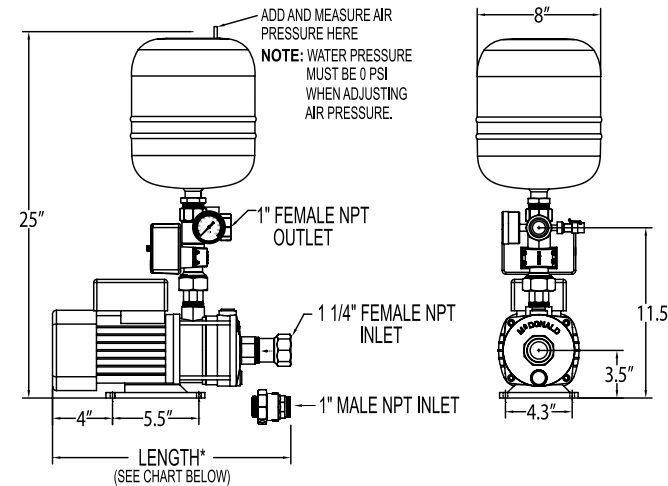

DuraMAC™ Model	Pump Boost	Length	Inlet	Voltage	Power	Pressure Reducing Valve recommended for installation with incoming pressure greater than:
<b>20 Gallon/Minute (GPM) Max</b>						
17035R020PC1	35 psi	15.26"	1"	120 - 60 Hz	1/2 HP	45 psi
17052R020PC1	52 psi	15.97"	1"	120 - 60 Hz	3/4 HP	28 psi
17070R020PC2	70 psi	16.68"	1"	230 - 60 Hz	1 HP	10 psi
<b>35 Gallon/Minute (GPM) Max</b>						
17040C035PC2	40 psi	15.43"	1.25"	230 - 60 Hz	1 HP	40 psi
17062C035PC2	62 psi	16.49"	1.25"	230 - 60 Hz	1 HP	18 psi
17078C035PC2	78 psi	17.55"	1.25"	230 - 60 Hz	1 1/2 HP	2 psi

DuraMAC™ pump lengths vary based on model. Many plumbing codes do not recommend system pressure exceeding 80 psi. Refer to local plumbing codes for maximum boosted pressure.

### Sizing Information

DuraMAC™ Booster Systems are designed to shut off when no flow is detected. Pump total pressure boost should be added to current system pressure to determine total system pressure when boosted.

Note: It is not recommended to exceed 80 PSI total boosted pressure.

Example: Incoming system pressure before boost = 30 PSI

$$\begin{array}{r} 30 \\ \text{Incoming} \\ \text{Pressure} \end{array} + \begin{array}{r} \text{Pump} \\ \text{Pressure Boost} \end{array} = \begin{array}{r} \text{Total Pressure} \\ \text{After Boost} \end{array}$$

Models Available:	Boost
17035R020PC1	+35
17040C035PC2	+40
17052R020PC1	+52
17062C035PC2	+62
17070R020PC2	+70
17078C035PC2	+78

$$\begin{array}{r} 30 \\ \text{Incoming} \\ \text{Pressure} \end{array} + \begin{array}{r} 40 \\ \text{Pump} \\ \text{Pressure Boost} \end{array} = \begin{array}{r} 70 \\ \text{Total Pressure} \\ \text{After Boost} \end{array}$$

Based on this example, the recommended model for this application is the 17040C035PC2.

For systems with fluctuating pressure, a pressure reducing valve is recommended to ensure system pressure stays below 80 PSI.

### Materials of Construction

Impellers	304 Stainless Steel
Pump Casing Inlet	301 Stainless Steel
Pump Casing Outlet	301 Stainless Steel
Pump Seal (stationary)	Silicon Carbide
Pump Seal (rotating)	Carbon / NBR
Diffuser	304 Stainless Steel
Suction Check Valve	No-Lead Brass
Pump Controller	No-Lead Brass

### 20 Gallon/Minute (GPM) Max

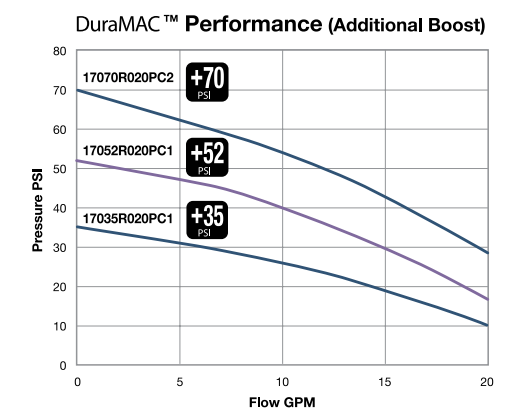

### 35 Gallon/Minute (GPM) Max

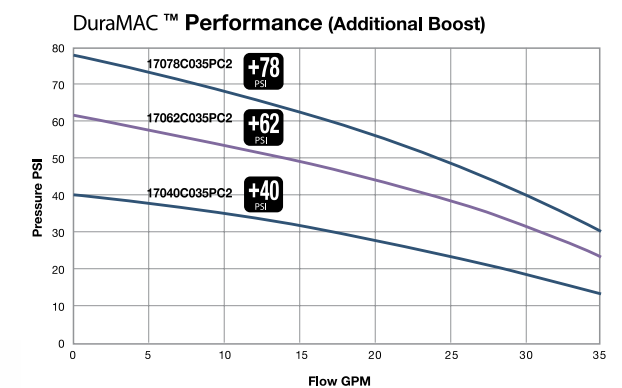

**Pressure Tank**  
Eliminates short cycling and helps accommodate thermal expansion.

**Pressure Gauge**  
Displays total system pressure

**Circuit Board**  
Sophisticated programming assures proper operation in all conditions.

**Digital Control**  
Single knob for simple pressure adjustment. Status light indicates standby, run and fault modes

**Transducer**  
Constantly monitors system pressure.

**Inlet w/Check Valve: Residential**  
No Lead Brass NPT thread with large wrench flats for easy & secure pipe connections

**Inlet w/Check Valve: Light Commercial**  
No Lead Brass NPT thread with large wrench flats for easy & secure pipe connections

**Union Swivel**  
Allows for 360° adjustment of discharge.

**Motor**  
Totally enclosed fan-cooled motor for quiet operation and low power consumption

**Pump**  
All stainless construction for tough water conditions.